

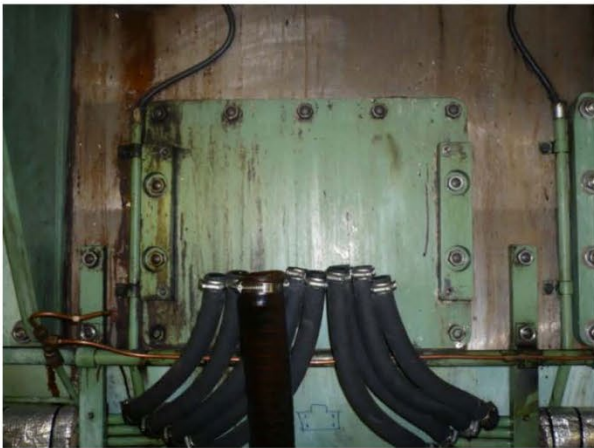

Existing OMD system.....

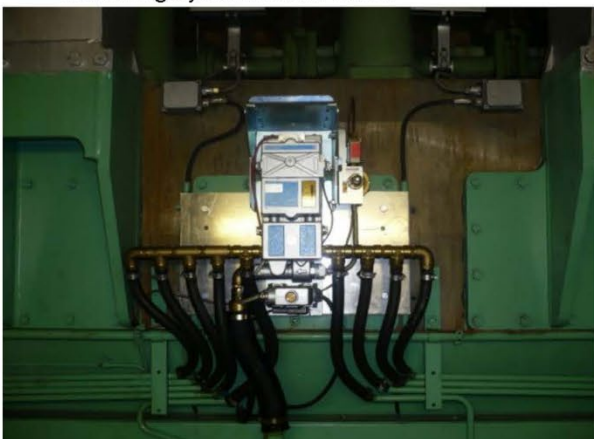

... existing system removed.....



Upgrading your Oil Mist Detector system to VISATRON

An example of replacing an old Mark 5 system to Visatron system:

When installing the Visatron oil mist detector VN 115/87 on a existing pipe arrangement for Mark 5 or MD-9, use the adapter kit . Connect the tubes between the adapter kit and the existing MD-9 pipe arrangement.

Pin connections:

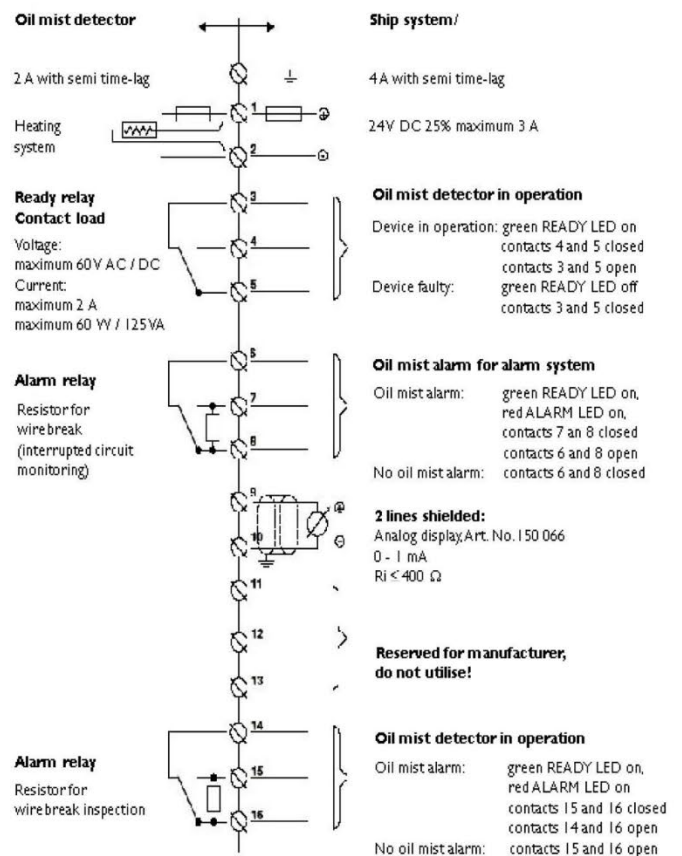

How to set the negative pressure:

The digital u- tube manometer is used to measure the negative mmH₂O pressure in the oil mist detector.

Setting point for the negative mmH₂O pressure is 60,00 mmH₂O.

We recommend checking the negative mmH₂O pressure every 30 days on the oil mist detector! The pressure is going to be measured at the inspection cover for the oil mist detector!

How to use:

1. When doing this procedure, the engine has to be turned off. Turn off the air pressure on the pressure regulator unit.
2. Unscrew the plug (part no. 10083) on the inspection cover (part no. 10088) located on the measuring head. Install the quick connection (part no. 10053.),
3. Press \ominus on the digital u- tube manometer- then 0,0 mmH₂O will be indicated in the display.
4. Press in the main connection into the quick connection, and start to adjust the adjusting screw on the pressure reducer until the display show 60,00 mmH₂O on the digital u- tube manometer.
5. When this is done, disconnect the digital manometer from the oil mist detector- the negative pressure is now ok.



Display on oil mist detector and function during normal operation:

- green READY LED is on
- the percentage of change in oil mist opacity with regard to basic opacity is shown on the opacity display
- TEST LED is off
- ALARM LED is off
- READY relay switched on
- ALARM relay switched off
- RESET button showing no function

Further opacity increase beyond alarm level marked by:

- blinking red ALARM LED
- READY relay is switched on
- ALARM relay is switched on

Alarm condition reset to basic state

- By pressing the RESET button
- If there is a device failure, e. g. breakdown of driving air supply (READY LED is off)

Display and function in case of a failure

A failure is shown by:

- green READY LED switched off
- the LED assigned to the failure is blinking in the opacity display
- TEST LED switched off
- ALARM LED switched off
- READY relay switched off
- ALARM relay switched off
- RESET button toggling from fault indication to opacity display and vice versa